

Context-Aware Fuzzy ArtMap for Received Signal Strength Based Location Systems

Uzair Ahmed, Andrey Gavrilov, Sungyoung Lee, Young-Koo Lee

Abstract—Received Signal Strength (RSS) based location systems are potential candidates to enable indoor location aware services due to pervasively available wireless local area networks and hand held devices. Inherently RSS based positioning is a multi-class pattern recognition problem. Previous researches have shown that Visibility Matrix based approach of modular classifiers improves location accuracy but costs longer periods of training and testing in development life cycle. We present a Context-aware Fuzzy ArtMap neural network that provides competitive location accuracy in comparison with modular approach while leveraging online and incremental learning capabilities to location system development life cycle.

I. INTRODUCTION

Location systems are posed to become common services in future mobile computing applications [8],[9],[12]. Satellite signal based GPS technology globally provides pervasive location awareness but suffers from degraded accuracy in indoor environments. Indoor positioning systems have costly infrastructure and special hardware devices mounted on the objects of interest such as Active Badge [13], Cricket [16], Active Bat [15] and Ubisense [14] location systems. Received Signal Strength based positioning technology offers economically viable solution to ever increasing users of hand held devices, e.g. PDAs and note books, connected through pervasive deployments of IEEE 802.11 standard Wireless LANs. Since signal strength measurements must be reported by the wireless network interface card, built into these devices, as part of standard compliance; location estimation using received signal strength (RSS) is a practical choice. [7],[10], [11],[17],[19], [20]. RSS based location awareness applications include, but are not limited to, a wide range of services to the end user like automatic call forwarding to user's location, robotic global localization, exploration and navigation tasks, finder, guiding and escorting systems, first hop communication partners, liaison applications, location based advertisement and positioning of entities in large warehouses. Basic concept behind WiFi RSS based location awareness is that received signal strengths, from different Access Points (APs), follow certain patterns at a particular location. These patterns are captured at each location and stored in a database so called 'Radio Map'. Later when some device reports the same pattern, it is matched with previously captured patterns and location of that device can be estimated. Process of capturing the RSS at particular locations in a site is called 'Site Calibration'. RSS based location estimation can be formalized as classification problem in the sense that location of a device is estimated based on

RSS feature vectors received by the target machine. Since these systems fundamentally assume that RSS feature vectors exhibit distinguishable patterns at different locations, therefore a pattern recognition machine can learn these patterns and estimate location of mobile users. Radio Map plays pivotal role in providing training feature space to pattern recognition machines.

In this paper we particularly concentrate on the issue of large scale location system development which has been addressed by some previous researches [20],[21]. Next section summarizes several approaches used for the development of Received Signal Strength based location systems. As discussed in section III, large scale location system employs several wireless Access Points that poses Visibility Problem to pattern recognition machines. Previously, Visibility Matrix based solutions have been employed to overcome this problem but that solution incurs tedious and time consuming training and testing phases [20],[21]. This paper presents a novel approach based on Context-aware Fuzzy ArtMap which leverages rapid location system development on large scale as well as competitive accuracy. A brief overview of Fuzzy Art and Fuzzy ArtMap and Context-aware Fuzzy ArtMap neural network systems are presented in section IV. Design and implementation details of our method as well as Visibility Matrix based Modular classifiers approach are given in section V along with comparative results analysis.

II. RELATED WORK

Different machine learning and pattern recognition techniques have been successfully employed to achieve similar location estimation accuracy; such as Bayesian classification and filtering, Support Vector Machines, GPS like triangulation, Kalman Filtering and finding Nearest Neighbors algorithms. Nearest Neighbors based pattern recognition technique and its variants have been used by pioneering works on RSS based location estimation. Microsoft's RADAR system reported 2.65 square meter distance error[7]. K. Pehlavan et al also used KNN technique and achieved 2.8 meter distance error[10]. Nearest Neighbor and its variants require a database of sample RSS readings at the estimation time for pattern matching. As the area and number of target locations grow, this size of the database dramatically increased and becomes impractical to achieve sufficient scalability. Some researches have also employed GPS like triangulation method for location estimation. Asim et al achieved 4.5 meter location estimation error in area of 60 square meters target[18]. Triangulation methods work on assumption that signal strength decays only as function of distance of receiver device from sender access points. Radio

Authors are associated with UC Lab, Kyung Hee University, Korea.
Primary Author Email: uzair@oslab.khu.ac.kr

Signal strength decay is function of several factors of indoor environments that affect the validity of this assumption. This fact severely affects the accuracy of such methods for indoor location estimation. Probabilistic approaches like Bayesian networks based solutions have also been employed for this problem but are computationally exhaustive and difficult to scale. Andrew et al reported 1.5 square meter distance error but only for 30 square meter area test bed [11]. As the area and number of target locations and wireless access points increase, the complexity of Bayesian structures grows and become computationally expensive. Neural Networks have been widely employed in pattern recognition problems due to their remarkable ability to tolerate noise and to generalize to patterns unseen at training time. Battiti et al have reported their research on using feed forward back propagation network on small scale (624 square meter area using 3 access points) location estimation system [19]. Learning Vector Quantization networks were used to develop location estimation system for 350 square meter area using 5 access points[17].

Due to small scale coverage ,there model assumes that all input signals are available at every location all the time. Practically this approach has limited applicability because in real life scenario some signals may not be available at estimation time due to Visibility Problem, as explained in next section.

III. THE VISIBILITY PROBLEM

We refer to signal availability of a particular access point at a given location as its 'visibility'. Large scale application of RSS based location estimation faces visibility phenomena. From location estimation stand point, one important aspect of indoor radio wave propagation is that not all access points are visible at all target locations all the time especially in case of large scale location system. We present empirical RSS visibility data in Fig. 1 which shows eight radar graphs of visibility probability of individual Access Points covering experimental site. We identify each access point using last four digits of its MAC (Media Access Code) address. These Access Points are deployed in Department of Computer Engineering building, third Floor, which is shown in Fig. 2 map. As it is obvious from these graphs, every Access Point is visible on a subset of 35 locations, shown as filled circles in Fig. 2. This is because radio signal of certain access point faces attenuation and fading effects and can be accessed within a specific area which is, normally, 150 square meters in indoor environments. Since a particular Access Point constitutes a distinguishing feature for pattern recognition machine, this implies that non-availability of a particular Access Point signal at given location can have adverse affect on location estimation. We demonstrate effect of non-availability of signals on location accuracy in section V. An intuitive approach is presented in [20],[21] which employs modular pattern recognition machines for location estimation in larger areas.

A. Modular Classifiers Approach

Careful observation reveals that there are related clusters of access points and locations where there exist a subset M_j of

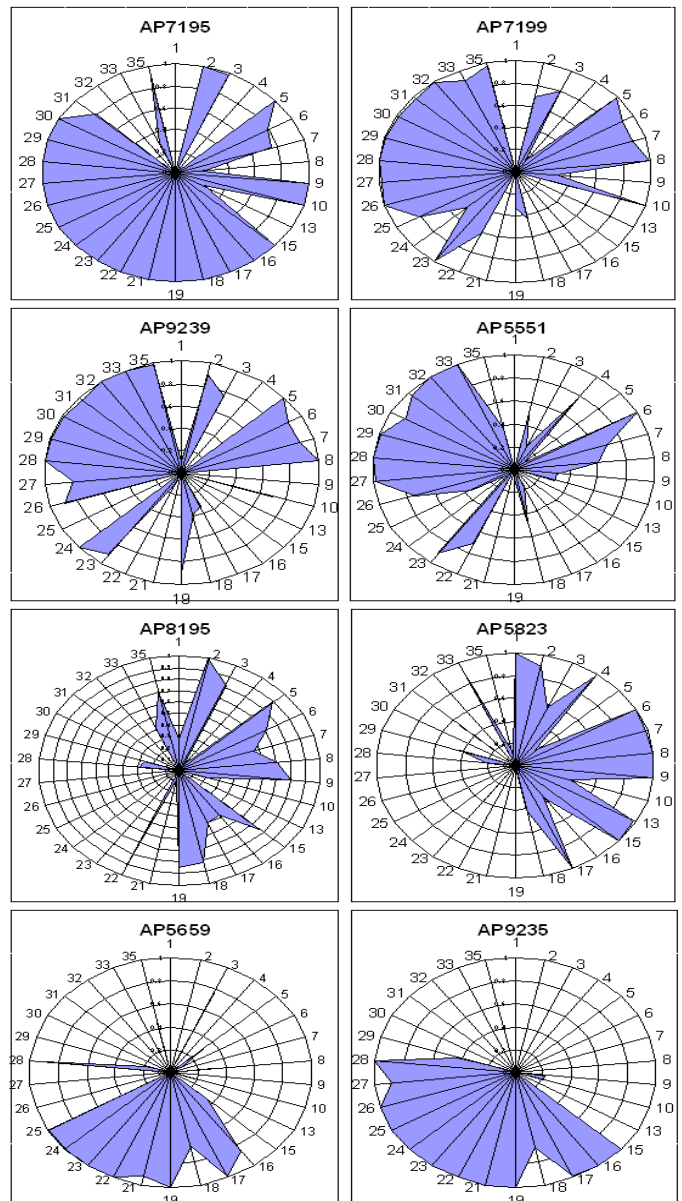

Fig. 1. Visibility graphs of eight access points at different locations in target area

all access points A_i which is visible at region r (a subset of all target locations L). These two related subsets are referred to as 'visibility cluster'. Visibility Matrix is used to generate 'visibility clusters' present in Radio Map feature space. Table I presents such clusters of target site.

TABLE I
VISIBILITY CLUSTERS BASED ON VISIBILITY MATRIX

Visible Access Points	Locations
AP7195AP7199AP9239	2,3,5,6,7,10,23,26,27,28,29,30,31,35
AP7195AP5551AP7199	2,6,7,22,23,26,27,28,29,30,31
AP7195AP8195AP5823	2,3,6,7,9,15,17
AP5551AP7199AP9239	2,6,7,8,23,26,27,28,29,30,31,32,33
AP7195AP5659AP9235	16,17,18,19,21,22,23,24,25,28

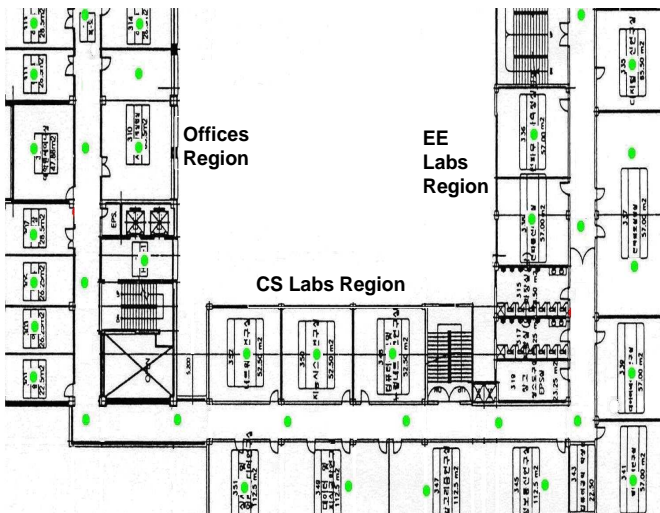

Fig. 2. Map of location system target site

Since visibility clusters correspond to set of access points which are visible at a set of locations, this information can be used to train separate pattern recognition modules for a particular cluster. Visibility Clusters provide basis for Visibility Matrix based Modular classifiers approach. In this scheme a specific module, which was trained a particular cluster, is presented with RSS input vector based on visibility rules. An example visibility rules is shown in Table II. In signal space availability or absence of signal from a particular access point is represented as 1 or 0 respectively. Corresponding region value, in region column, represents coarse grained location information of device in location space. This matrix provide binary decision rules for inferencing which module to be invoked when signal from different access points are detected.

TABLE II

VISIBILITY RULES: VISIBILITY MATRIX BASED MODULAR APPROACH

7195	7199	9239	5551	5823	5659	9235	Module
1	1	1	0	1	0	0	M1
0	1	1	0	0	1	1	M2
1	0	0	0	1	0	0	M3
1	0	0	0	1	1	1	M4
1	0	0	0	0	1	1	M5

B. Context-aware Classifier Approach

In this paper we present a Context-aware Fuzzy ArtMap neural network to effectively handle Visibility problem as well as achieving online and incremental learning. As explained previously; a particular set of access points, or visibility cluster, represent a set of locations. This implies that each set of Access Points in Visibility Matrix is important context that can improve pattern recognition capability of the machine. Therefore, instead of training a separate pattern recognition module for each visibility cluster we incorporate this contextual information into one classifier thus making it Context-aware. We implemented this capability in Fuzzy ArtMap system as presented in next section. Besides competitive location

accuracy, as shown in section V, novelty of this approach is exhibited in following aspects which cannot be realized using previous approaches. Detailed treatment of how we achieve these capabilities is given in [22].

1) *Dynamic expansion of location system:* Flexible and Dynamic expansion of location system is easy and straight forward in our approach. By expanding location system flexibly and dynamically we mean incrementally learning new locations in real time thus increasing area by including more target locations into system. In order to achieve this purpose, using previous approaches, Radio Map feature space is required to be extended to include training RSS pattern-location mapping and then retraining of classifier with extended radio map. In case of retraining with new feature space, most of 'off line training' based classifiers face with the 'Stability plasticity dilemma'. That means learning new pattern-class mappings causes erosion of previous knowledge acquired by classifier during early training. Other techniques overcome this problem by retraining classifier with whole Radio Map (that includes both old and new training data). Fuzzy ArtMap is capable of incremental learning and ensures stable learning of categories while exposed to new set of pattern-class pairs [5]. This capability allows flexible learning of new locations without requiring retraining with whole new feature space.

2) *Rapid Location System Development:* Fuzzy ArtMap classification system learns pattern class pairs online, which implies that Radio Map feature space need not to be created prior to model training. This property enables such location systems that can be built without calibration phase and model training phase. Previous approaches incorporate *off line* training pattern recognition methods which incurs tedious site calibration phase onto development life cycle as shown in Fig. 3. By virtue of online learning capability of Fuzzy ArtMap this approach removes site calibration phase and off line training phase from development life cycle, as shown in Fig. 4, and realize rapid location system development.

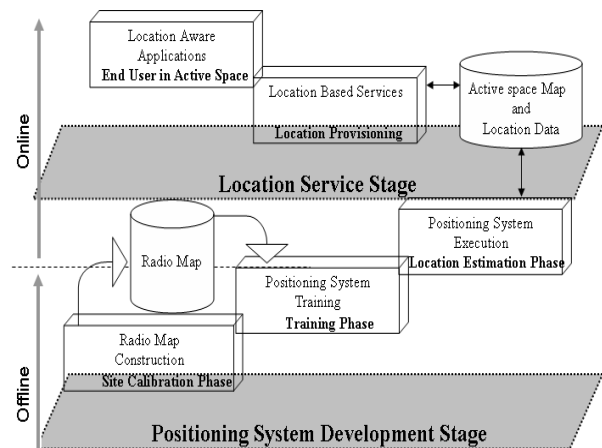

Fig. 3. Location System Development Life Cycle: Previous Approaches

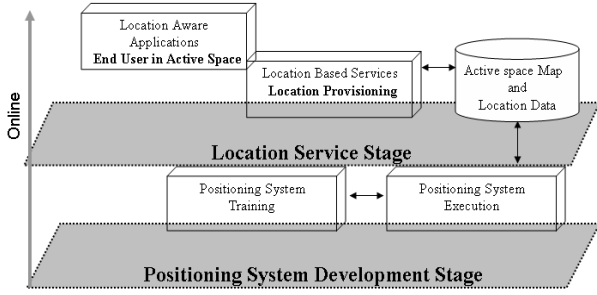

Fig. 4. Our Approach: Short Development Life Cycle

IV. FUZZY ART, FUZZY ARTMAP AND CONTEXT-AWARE FUZZY ARTMAP

Fuzzy Art neural network performs online unsupervised clustering of an arbitrary stream of analog or binary input patterns. It is combination of ART-1 network [2], which can learn to categorize only binary patterns, and fuzzy set theory. Here we briefly explain basic learning algorithm of Fuzzy Art network, detailed discussion of its dynamics can be found in [3]. Fuzzy Art learning is governed by three parameters i) choice parameter $\alpha > 0$ ii) learning rate $\beta \in [0, 1]$ and iii) vigilance value $\rho \in [0, 1]$. Besides these three parameters network requires M , dimensions of input vector, and N , number of categories, to be specified prior to its operation. Network initialization creates N neurons in F_1 layer and M neurons in F_2 layer. A synaptic connection is created that connects each F_1 layer neuron with all F_2 layer neurons. Each F_2 layer neuron represents a category in input feature space encoded in term of adaptive synaptic weights, also called Long Term Memory (LTM) traces, $\mathbf{W}_j = (w_{j1}, w_{j2}, w_{j3} \dots w_{jM})$. During initialization network assigns 1 to all synaptic connection weights which shows that all categories are uncommitted. Before presenting network with input vectors, an optional preprocessing of input vector is performed. Fuzzy Art suffers from category proliferation problem as characterized by Moore [1]. In order to overcome this problem a normalization technique, namely Complement Coding, is proposed by Carpenter et al in [3]. This normalization technique enables network to overcome category proliferation problem as well as to reduce effect of presentation frequency of an input pattern and order of presenting input patterns as explained in [4].

Fuzzy ArtMap is more general ArtMap (also called Predictive Art)[4] network which can handle analog input patterns and performs online incremental supervised learning of pattern-class pairs presented in arbitrary order. It is Adaptive Resonance Theory (ART) based Self organizing neural network for real time autonomous learning environments. Fuzzy ArtMap system is composed of a pair of Fuzzy ART networks (Fuzzy ART_a and Fuzzy ART_b) which employ combination of fuzzy logic and Adaptive Resonance Theory [5] to establish stable recognition categories in response to temporal stream of analog RSS input patterns. Rigorous characterization of Fuzzy ART and Fuzzy ArtMap neural networks can be found in [3]

and [4]. Fig. 5 shows topological structure of Fuzzy ArtMap neural network.

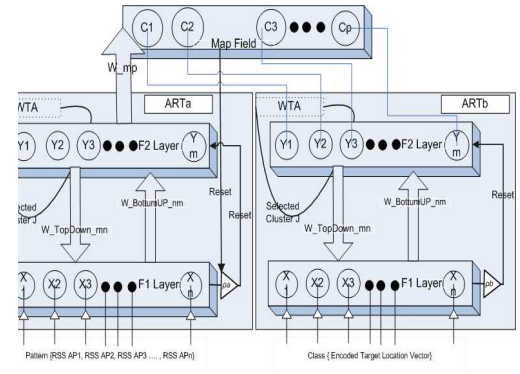

Fig. 5. Fuzzy ArtMap Network Topology

Fuzzy ART modules ART_a and ART_b self-organize category grouping for separate input sets v (feature RSS vector reported by mobile device) and e (encoded location information). Map Field is inter-ART module that controls the learning of an associative map from ART_a recognition categories to ART_b recognition categories. This is achieved by connecting F_2 Layer, so called F_2^b , neurons of ART_b to Map Field nodes with on-to-one, non-adaptive links in both ways. On the other hand each F_2 layer, so called F_2^a , neuron of ART_a is connected to all Map Field nodes via adaptive links. Since Map Field represents a mapping from both F_2^a and F_2^b it is referred to as F^{ab} . This map does not directly associate feature vectors with encoded class labels but rather associate the compressed codes of groups of v and e . During learning pattern-class pairs, if a mismatch occurs at Map Field between ART_a category and ART_b category then system increases vigilance parameter of ART_a so that ART_a can categorize this pattern in different category or can create new category for this pattern that matches ART_b class category. This mechanism allows network to capture novel features that can be incorporated through learning new ART_a recognition category. Activation of Map Field results in output signal from each F^{ab} node, a vector corresponding to target location, that eventually becomes output of Fuzzy ArtMap network. Learning RSS-location pair occurs if Fuzzy ArtMap network is presented with both RSS input vector and target location vector. In Location estimation occurs in case only RSS input vector is presented to network. Activation of F^{ab} occurs both in case of learning mode and estimation modes. Match tracking and orienting subsystem allows Fuzzy ArtMap network to establish different categories for similar RSS inputs at ART_a and also allow very different RSS inputs to form categories that make same location estimation. This is achieved by activating orienting subsystem only when ART_a makes a location estimate that does not confirm with actual location provided to ART_b. This condition starts match tracking by adjusting ART_a vigilance parameter in such a way that estimation error is removed. We present a Self-scalable and Context-aware variant of original Fuzzy ArtMap system as discussed in the following.

A. Self-Scalability

We adapt a simplified version of Fuzzy ArtMap, presented in [6], which employs only one Fuzzy Art network instead of two with same learning and recall performance as original Fuzzy ArtMap. Original Fuzzy ArtMap specification requires that capacity of network, in terms of number of categories (locations in our case) that network can learn, need to be fixed prior to learning. Prior fixation of number of categories means that once RSS patterns of a 'fixed' number of locations (with respect to the capacity of network) are learned by network, then more locations cannot be learned (or incorporated) into that network. This limits the application of original Fuzzy ArtMap in terms of dynamically expanding the location system. We tailored original Fuzzy ArtMap in our implementation such that it do not require capacity of network to be fixed prior to learning and allows network to self-scale itself as new categories (locations) are presented to it. Implementation of our self-scalable fuzzy ArtMap network is available as open source [23]. Refer to [22] for rigorous characterization of self-scalability in Fuzzy ArtMap system and its impact on location system development.

B. Context-awareness

By Context-awareness we mean to enable a classifier such that it can differentiate among different input spaces. This is achieved by embedding context knowledge, visibility cluster in our application, into Fuzzy ArtMap classifier. This is achieved by introducing Context Field subsystem into original Fuzzy ArtMap neural network as can be seen in Fig. 6. Learning dynamics, shown in Fig. 7, of Context-aware Fuzzy ArtMap are similar to original one except that it maintains contextual knowledge as a special hash table where context code, visibility cluster in this case, represents key and respective F_2 nodes become its values.

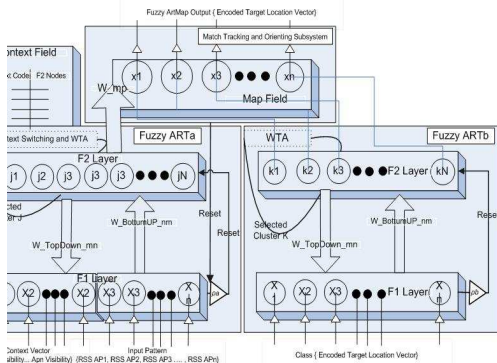

Fig. 6. Context-aware Fuzzy ArtMap Network Structure

V. IMPLEMENTATION RESULTS

We conducted extensive experiments in 1240 square meter area of Computer Engineering Department Building, map of which is shown in Fig. 2. Pocket pc (HP iPaq 1450 model) and laptops were used for getting received signal strength vectors from different Access Points at all target locations. Separate

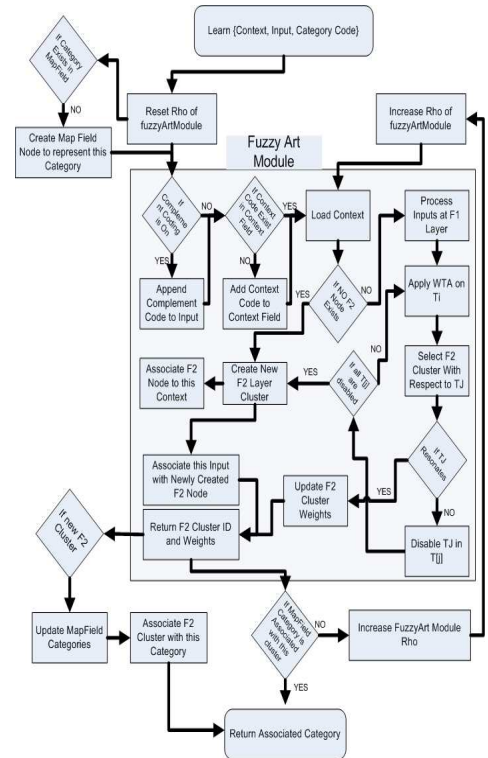

Fig. 7. Context-aware Fuzzy ArtMap Learning Algorithm

training and testing data sets, Radio Maps, for both *off line* and *online* training based classifiers were collected over five days by different people. Inputs were presented to each classifier as predefined ordered sequence of RSS of a set of Access Points. Target locations are represented as unique ID at application level and as binary codes for classifiers. We measure location estimation error in terms of absolute deviation of location estimate from actual location. Absolute deviation is measured as Mean Absolute Error (MAE).

For Fuzzy ArtMap experiments we selected different learning and recall parameters α , β and ρ as .1, .5 and .8 respectively. Table III presents detailed training results of Context Aware Fuzzy ArtMap network for each context or cluster.

TABLE III
CONTEXT-AWARE FUZZY ARTMAP RESULTS

Context	F2 Clusters	Epochs	Training MAE	Test MAE
5	20	3	0	.42
4	27	3	0	1.08
3	36	3	0	.51
2	29	3	0	.89
1	26	3	0	.85

In parallel to Fuzzy ArtMap based location system we implemented two other neural network models for our location system i) Multi Layer Perceptron (MLP) and ii) Learning Vector Quantization (LVQ), in order to evaluate relative location estimation performance with previous approaches [17][21] and [19][20]. Table IV presents performance of non-modular network as well as individual MLP modules, indicated as mMLPx, on both training and test radio map.

TABLE IV
MULTI LAYER PERCEPTRON RESULTS (BOTH MODULAR AND NON
MODULAR)

Module	Structure	Epochs	Training MAE	Test MAE
MLP	10-70-35	2000	0.021	1.0
mMLP1	5-40-8	100	0	0.4140
mMLP2	4-80-8	100	0	0.7286
mMLP3	4-50-25-10	100	0.0184	0.556
mMLP4	4-50-9	100	0.0047	0.4957
mMLP5	4-30-15-6	100	0	0.9806

Performance of non-modular LVQ network as well as individual LVQ modules, indicated as mLVQx, on both training and test radio map is given in Table V.

TABLE V
MODULAR LEARNING VECTOR QUANTIZATION RESULTS

Module	Structure	Epochs	Training MAE	Test MAE
LVQ	10-100-35	50	0.018	2.6
mLVQ1	5-30-8	100	0.03	0.5571
mLVQ2	4-30-8	200	0.009	0.7214
mLVQ3	4-40-10	100	0.027	0.9760
mLVQ4	4-40-9	200	0.057	0.4087
mLVQ5	4-40-6	100	0.048	1.25

As it is obvious from these results, Visibility Matrix based Modular approach improves overall location accuracy but takes longer periods of training and testing as well as extensive human involvement to collect empirical data and establish visibility clusters. Context-aware Fuzzy ArtMap system takes only 3 epochs to achieve 0 MAE and, at the same time, makes optimum number of F_2 layer clusters. More importantly it does not require long periods of training and testing. Summarized location estimation results of non-modular, modular and Context-aware Fuzzy (CA-FAM) ArtMap are given in Table V.

TABLE VI
SUMMARIZED COMPARATIVE RESULTS ON TRAINING AND TEST RADIO
MAPS

Method	Training MAE	Test MAE
FAM	0	1.06
CA-FAM	0	0.72
MLP	0.021	1.03
Modular MLP	0.01	0.63
LVQ	0.018	2.60
Modular LVQ	0.03	0.79

VI. CONCLUSIONS

In this paper we presented a Context-aware Fuzzy ArtMap system and demonstrated its application on development of large scale Received Signal Strength based location systems. Large scale location systems face with intermittent visibility of signal sources especially in indoor environment. Modular classifier approach effectively models this problem using a Visibility Matrix but requires longer time to develop such systems. We compared context-aware classifier approach with modular approaches in two respects; *location estimation accuracy* and *development time*. Results show that Context-aware Fuzzy ArtMap provides competitive location estimation

accuracy as well as fastest development time in comparison with previous approaches.

VII. ACKNOWLEDGEMENT

This research was supported by the MIC(Ministry of Information and Communication), Korea, under the ITRC(Information Technology Research Center) support program supervised by the IITA(Institute of Information Technology Advancement), (IITA-2006-(C1090-0602-0002))

REFERENCES

- [1] Moore. B ,”ART and pattern clustering”. In Proceedings of the 1988 connectionist models summer school, pp. 174-183, 1988
- [2] Carpenter, G.A., Grossberg, S., ”Adaptive Resonance Theory”, The Handbook of Brain Theory and Neural Networks, Second Edition. Cambridge, MIT Press, pp. 87-90, 2003
- [3] Carpenter, G. A., Grossberg, S., and Rosen, D. B. ”Fuzzy ART: Fast stable learning and categorization of analog patterns by an adaptive resonance system”, Neural Networks, Vol. 4, pp. 759-771, 1991
- [4] Carpenter, G.A., Grossberg, S., Reynolds, J.H., ”ARTMAP: Supervised real-time learning and classification of nonstationary data by a self-organizing neural network”, Neural Networks, pp. 565-588, 1991
- [5] Carpenter, G.A., Grossberg, et al, ”Fuzzy ARTMAP: A neural network architecture for incremental supervised learning of analog multidimensional maps”, IEEE Transactions on Neural Networks, Vol. 3, pp. 698-713, 1992
- [6] M. Teresa Serrano-Gotarredona , Bernabe Linares-Berranco, Andreas, G. Andreaou, ”Adaptive resonance theory microchips-Circuit Design Techniques”, Springer 1st edition, May 5, 2005
- [7] P. Bahl, et al. ”RADAR: An in-building RF-based user location and tracking system.” In IEEE INFOCOM 2000, pp. 775-784, March 2000
- [8] R. Want and B. Schilit, ”Expanding the horizons of location-aware computing”, IEEE Computer, pp.31-34, August 2001.
- [9] Cynthia et al, ”Challenges in Location-Aware Computing” Published by IEEE ComSoc, 2003
- [10] K. Pehlavan et al, ”Indoor Geolocation Science and Technology”, IEEE Communications Magazine, 2002
- [11] Andrew et al, ”Using Wireless Ethernet for Localization”, 2002 IEEE/RJS International Conference on Intelligent Robots and Systems
- [12] Mike Hazas et al, ”Location-Aware Computing Comes of Age,” Computer, vol. 37, pp. 95-97, February 2004.
- [13] Roy et al, ”The active badge location system”, ACM Transactions on Information Systems (TOIS) Volume 10, Issue 1, pp: 91-102
- [14] UbiSense, ”Local position system and sentient computing.” <http://www.ubisense.net/>
- [15] Andy Ward et al, ”A New Location Technique for the Active Office”. IEEE Personal Communications, Vol. 4, No. 5, pp. 42-47, October 1997
- [16] N.B. Priyantha et al, ”The Cricket Location-Support System,” Proc. 6th Ann. International Conference on Mobile Computing and Networking, ACM Press, New York, 2000.
- [17] Tomoaki Ogawa, Shuichi Yoshino, and Masashi Shimizu, ”Location Determination Method for Wireless Systems Based on Learning Vector Quantization”, NTT Network Innovation Laboratories, Vol 1, No. 9, Japan
- [18] Asim Smailagic et al, ”Location Sensing and Privacy in a Context Aware Computing Environment”, Pervasive Computing, 2001.
- [19] Roberto Battiti et al, ”Neural Network Model for intelligent networks: deriving the Location from signal patterns”, The First Annual Symposium on Autonomous Intelligent Networks and Systems 2002
- [20] Uzair Ahmad et al, ”In-building Localization using Neural Networks”, IEEE International Conference on Engineering of Intelligent Systems, 22-23 April 2006, pp: 1-6
- [21] Uzair Ahmad et al, ”Modular Multilayer Perceptron for WLAN Based Localization”, IEEE International Joint Conference on Neural Networks, Vancouver, Canada, July 2006, pp: 3465- 3471
- [22] Uzair Ahmad et al, ”Self-scalable FuzzyArtMap for Received Signal Strength based Location Systems”, International Symposium on Neural Networks, Nanjing, China, June 2007 (Accepted to be published)
- [23] CompoNet, Componentization of Neural Networks, Component Technology Open Source Project. <http://sourceforge.net/projects/componet/>