

A QoS Provision Architecture for Mobile IPv6 Using RSVP

Zhaowei Qu, Choong Seon Hong

School of Electronics and Information, Kyung Hee University, 449-701 Korea
gzw@networking.kyunghee.ac.kr cshong@khu.ac.kr

Abstract. It has become very significant to enhance Quality of Service (QoS) capabilities of real-time data transmission in the Internet. The Resource Reservation Protocol (RSVP) provides a signaling mechanism for end-to-end QoS in Integrated Services Internet. Provision of QoS in wireless networks is more complex than in wired networks because of frequent mobility of mobile users. In this paper, in order to obtain more efficient use of scarce wireless bandwidth, increase data rate and reduce QoS signaling delay and data packet delay during handoff in Integrated Services Internet, we propose a novel scheme that improves the efficiency using a Hierarchical Mobile Agents Tree (HMAT) based on the definition of new option called QoS Object Option (QOO). Mobile agents are required to manage QOO, resource reservation and other mobility related tasks on behalf of mobile hosts. This scheme is based on Mobile IPv6.

1 Introduction

Mobile users want to enjoy multimedia and other real-time services in the Internet. Thus the Internet Engineering Task Force (IETF) has introduced the Mobile IPv4 [1] and Mobile IPv6 [2] to interoperate seamlessly with protocols that provide real-time services in the Internet. Resource Reservation Protocol (RSVP) [3] [4] is a resource reservation setup protocol designed for a wired network, provides resource reservation signaling support and has been facing a great challenge due to the mobile hosts. Provision of end-to-end QoS in wireless networks is more complex [5] than in wired networks because of the user mobility. Especially as recent wireless networks have been implemented based on micro-cell and handoff takes place more frequently, making QoS guarantees becomes more difficult.

In this paper, we will propose a novel scheme using the Hierarchical Mobile Agents Tree (HMAT) based on the definition of new option called QoS Object Option (QOO) [11] to improve the efficiency. Mobile agents of HMAT manage QOO, resource reservation and some tasks related with mobility on behalf of mobile hosts.

In section 2, we provide related works, and in section 3, we describe our scheme to provide a new QoS mobility support in the Internet. In section 4, we present simulation results to prove the efficiency of our scheme. Finally, we give our conclusions in section 5.

2 Related Works

Recently there have been some works [6-12] about RSVP support in mobile and wireless networks. The focus of these researches is the handoff management problem. In [6], the architecture for QoS using RSVP in the Integrated Services Packet Network has been described, and a resource reservation protocol, MRSVP, for mobile hosts has been proposed by Talukdar. The main feature of this protocol is the concept of active and passive reservations that is used to provide mobility independent service guarantees. However, the architecture requires a mobile to know all the subnets it will be visiting. The mobile obtains the identity of the proxy agents, which help with mobile RSVP in all the subnets, using a proxy discovery protocol. The mobile instructs the proxy agent in the region it is currently located to make passive reservations with all the proxy agents in all other regions. Four additional messages are used in addition to the messages already present in RSVP. The drawback of this architecture is that a mobile knows the addresses of all the subnets it is going to move into and which is not always possible. It also places a burden of finding the proxy agents in all these subnets on the mobile. In [7], the proposal proposed by Mahadevan also suggests two kinds of resource reservations that contain passive reservation and active reservation. This architecture is based on the assumption that a base station knows the addresses of the base stations in all the neighboring cells, and then solves the burden placing on the mobile host in [6].

In [8], the protocol proposed by Zhang works by combining pre-provisioned RSVP tunnels with mobile IP routing mechanism. However, the tunnels with Mobile IP may result in triangle routing problem, and the pre-provisioned RSVP tunnels are not flexible and efficient. In [9], Chen describes another signaling protocol for mobile hosts to reserve resource in Integrated Services Internet. This protocol extends the RSVP model based on IP Multicast Tree. The mobility of a host is modeled as a transition in Multicast group membership. The Multicast Tree is modified dynamically every time a mobile host is roaming to a neighboring cell. This protocol proposes that a mobile host has to make Conventional Reservation along the data flow from the sender to current location in current cell and Predictive Reservation along the Multicast Tree from the source to the neighboring cells surrounding the current cell of mobile host. Before a mobile receiver launches a reservation, the mobile host should join a Multicast group in which the sender is the root of Multicast Tree through mobile proxy also informs all of the neighbor mobile proxies surrounding the current location to join the Multicast group. Once these new branches of the Multicast Tree have formed, path messages from the sender are forwarded to mobile proxies along the Multicast Tree. Upon receiving the path messages, current mobile proxy and neighbor mobile proxies will issue reservation requests. Conventional Reservation message from the current mobile proxy is propagated toward the sender along the Multicast Tree and the Predictive reservation messages from neighbor mobile proxies are followed in the same manner. The data packets can be transmitted over the Conventional Reservation link. Figure 1 shows an example for reservations. When the mobile receiver is moving from one location to a neighbor location, the Multicast Tree will be modified. After the new Multicast Tree is formed, the Predictive Reservation from Merge Point to this mobile proxy is switched into

Conventional Reservation. On the other hand, the original Conventional Reservation from the Merge Point to the original mobile proxy is switched to Predictive Reservation, and some new Predictive Reservations along the new Multicast Tree from the source to the neighboring cells surrounding the current cell of mobile host should be set up. Then the flow of data packets can be transmitted over that new Conventional Reservation link. In this protocol, there are 8 additional messages presented to complete the functions of Multicast Tree modifying and RSVP setting up.

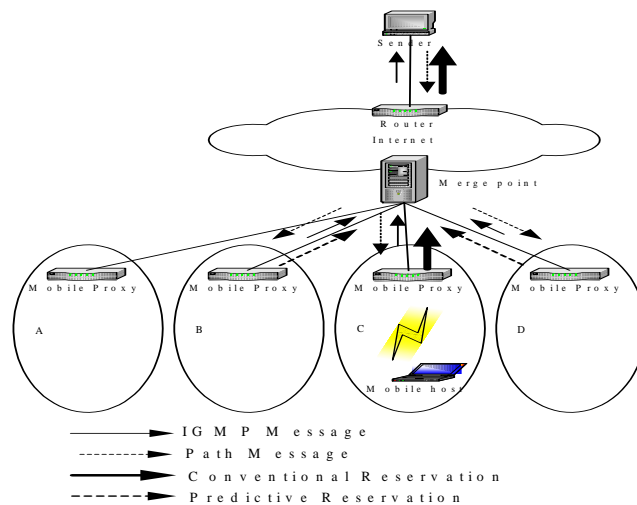

Fig. 1. RSVP Mobility Based on Multicast Tree

Talukdar [6], Mahadevan [7] and Chen [9] also have a challenge that is how to predict the Mobile node's movement behavior so that pre-reservations can be done only in necessary cells. If prediction is not available, resource pre-reservations can have to be performed in all neighboring cells, which wastes resource. Although this waste may be alleviated through definition of new RSVP reservation models (like Active Reservations and Passive Reservations, Conventional Reservations and Predictive Reservations), the expense would be extra protocol complexity and increasing the QoS signaling delay, the data packet delay.

In [10], Qi proposes a Flow Transparent Mobile IP and RSVP integration scheme. When the mobile host moves from subnet A to subnet B, a new reservation from Router at subnet B to a Nearest Common Router will be added, and the original reservation from Router at subnet A to the Nearest Common Router will be obsolete. However, it is difficult to choose a proper router as the Nearest Common Router, and this scheme is not feasible.

In [11], when the mobile node is receiver in Access Network, the Binding Acknowledgment has to be used so that the proposal is not efficient, and has more data packet delay.

In [12], the handoff message has to be used only for Access Network, thus the flexibility is not better.

3 Proposed Scheme

In this section we propose a framework using a Hierarchical Mobile Agents Tree (HMAT) based on the definition of new option called QoS Object Option (QOO) [11] to get more efficient use of scarce wireless bandwidth, minimize the QoS signaling delay, the data packet delay and losses and get higher data rate during handoff in mobile environment.

3.1 QoS Object Option (QOO)

This option is included in the hop-by-hop extension header of certain packets carrying Binding Update message in Mobile IPv6. The composition of a QOO [11] is shown in Table 1 by using TLV format. A QoS Object is an extension of RSVP QoS that can be used not only in the Access Network, but also in the Core Network to get a better QoS support.

Table 1. Composition of a QoS Object

| | | | | | |
|--|--------------------|---|-------------------------|-------------------------|-------------------------|
| | 0 | 0 | 1 | Option type 5bit | Option Data Len 8bit |
| Reserved | Object Length 8bit | | | QoS requirement 8bit | |
| Max Delay (ms) 16bit | | | Delay Jitter (ms) 16bit | | |
| Average Data Rate 32bit | | | | | |
| Burstiness : Token Bucket Size 32bit | | | | | |
| Peak Data Rate 32bit | | | | | |
| Minimum Policed Unit 32 bit | | | | | |
| Maximum Packet Size 32 bit | | | | | |
| Values of Packet Classification Parameters | | | | | |

In QOO, the QoS Requirement describes the QoS requirement of the MN's packet stream, the fields Max Delay and Delay Jitter specify the delay that packet stream can tolerate, the fields Average Data Rate, Burstiness, Peak Data Rate, Minimum Policed Unit and Maximum Packet Size describe the volume and nature of traffic that the corresponding packet stream is expected to generate, the field Packet Classification Parameters provide values for parameters in packet headers that can be used for packet classification.

3.2 Hierarchical Mobile Agents Tree (HMAT)

Recently wireless networks have been implemented based on micro-cell and the moving host may cross small cells very often. Therefore handoff takes place more frequently. Then the QoS signaling delay, the data packet delay will increase and the data rate will decrease and the packet losses, possible service degradation may occur.

Our hierarchical mobile agents tree is aimed at solving these problems. HMAT means Hierarchical Mobile Agents Tree that contains mobile agents of several levels, and can be chosen and configured in any way as the network administrator thinks appropriate.

3.3 Mobile Agent

A mobile agent is an entity that manages QOO, resource reservations and other mobility related works. Mobile agents in a HMAT can be divided into two kinds. First type is the mobile agent in a domain and the first level of the HMAT, similar to home agents in Mobile IPv6, manages QOO for QoS support, processes the mobile related RSVP messages and maintains the mobile soft state for mobile hosts, is organized into a hierarchy to handle local movements of Mobile hosts within the domain. And the second type is the mobile agent in higher levels of the HMAT can manage QOO for QoS support, merge path message and reservation message. This kind of mobile agent will be a point where merging causes no resulting state change when the Path or Resv refresh message establish path or reservation state respectively along the new route after a handoff takes place. The first type mobile agent's function includes the second type mobile agent's function.

3.4 QoS Support in HMAT

There are two scenarios in QoS support based on our HMAT scheme.

When the Mobile Node (MN) is sender, the Correspondent Node (CN) is receiver, after a handoff, the MN sends a Binding Update with QOO to CN along HMAT, in the first level mobile agent, this agent examines QOO and immediately performs the resource reservation, sends the new path message to CN with the same source flow identity as the one before handoff, and also sends the Binding Update with QOO to the CN. Then the path message can be merged at some mobile agent that has already a path state in HMAT for that flow which is created before. This will make RSVP to have a Local Repair for sender route. Therefore the mobile agent sends a Resv message associated with the flow along the new path in HMAT to the MN upstream at once, also sends the Binding Update with QOO to the CN downstream. The flow path reserved resources previously from the mobile agent to the CN can be reused. After the CN receives the Binding Update with QOO, the CN will send the Binding Acknowledgment to the MN's current location through the HMAT. Then the data packets will be sent from the MN's new location to the CN. Figure 2 shows this scenario.

When the MN is receiver, the CN is sender, and a handoff occurs, the MN sends a Binding Update with QOO upstream along HMAT to some mobile agent that has already the path state for the flow that is created before. This mobile agent examines

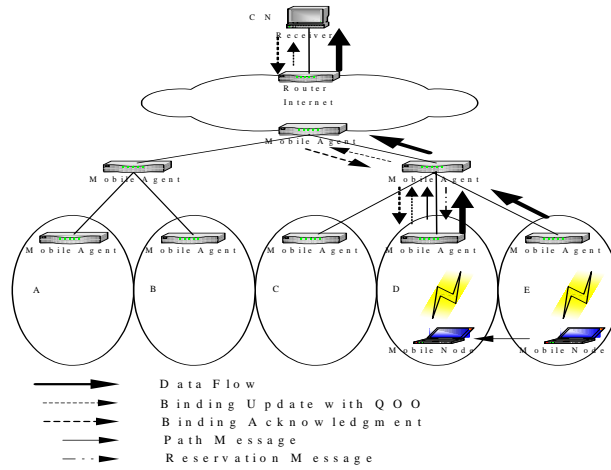

Fig. 2. MN as Sender in HMAT Model

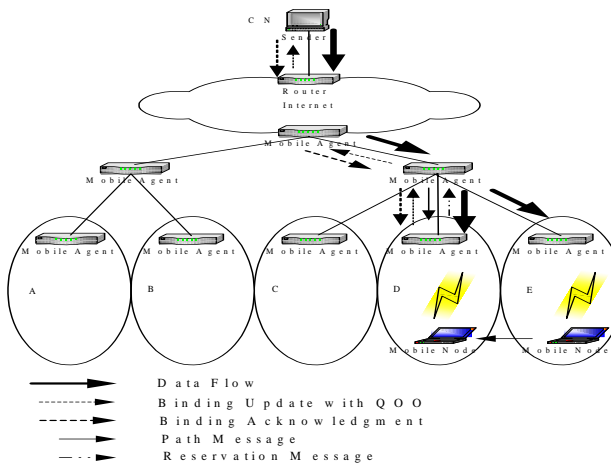

Fig. 3. MN as Receiver in HMAT Model

QOO and immediately performs the resource reservation, sends the new path message to the MN downstream and at the same time sends the Binding Update with QOO upstream to the CN. When the MN receives the new path message, it sends a Resv message associated with the flow along this path in HMAT to the mobile agent. The flow path reserved resources previously from the mobile agent to the CN can be reused. And after the CN receives the Binding Update with QOO, the CN will send the Binding Acknowledgment to the MN's current location through the HMAT. Then the data packets will be sent from the CN to the MN's new location. Figure 3 shows this scenario.

Our scheme provides smooth handoff QoS provision without extra QoS delay. It is sure that the RSVP messages traverse shorter than the Binding Update and Binding Acknowledgment, because the RSVP messages traverse between some mobile agent of HMAT and the MN in a part of the route where the Binding Update and Binding Acknowledgment have to traverse between the CN and MN. Therefore the RSVP renegotiation can be finished before the CN is updated with MN's new care-of address, especially when there are congested links within the path between the CN and the mobile agent of HMAT. Thus resources have been set up before CN starts to send or receive packets with MN's new location. In other words, all packets subsequently between MN's new location and the CN will be offered QoS as desired and no any extra handoff delay may occur due to handoff. But in Multicast Tree scheme [9], when the handoff takes place, at first, the MN sends the Binding Update to the CN and receives the Binding Acknowledgment from the CN, then the Multicast tree should be modified to set up new QoS, at last, the data packets can be transmitted between the MN and CN in Mobile IPv6. We use Rational Rose 2000 to show the Sequence Diagram of the Multicast Tree scheme in Figure 4, the Sequence Diagram of our HMAT scheme in Figure 5 and Figure 6.

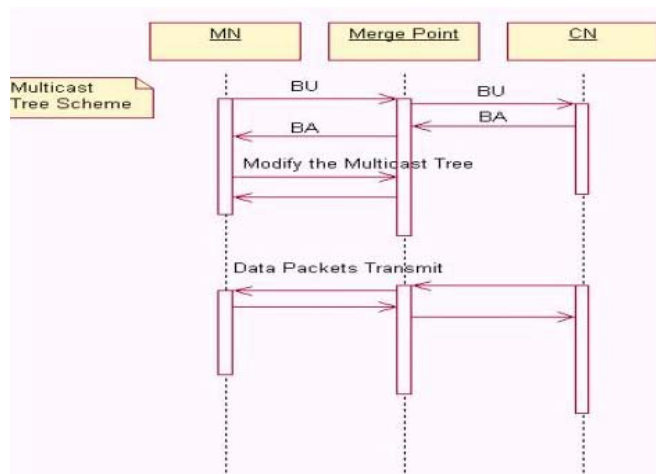

Fig. 4. Sequence Diagram of the Multicast Tree Scheme

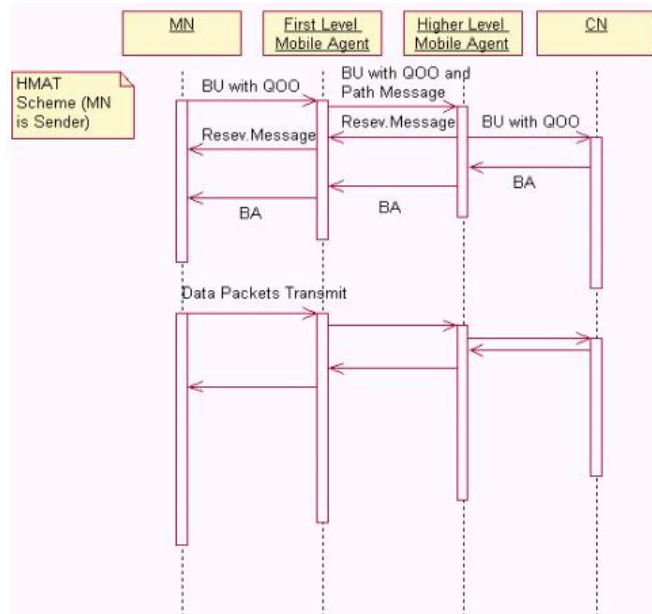

Fig. 5. Sequence Diagram of the HMAT Scheme (MN is Sender)

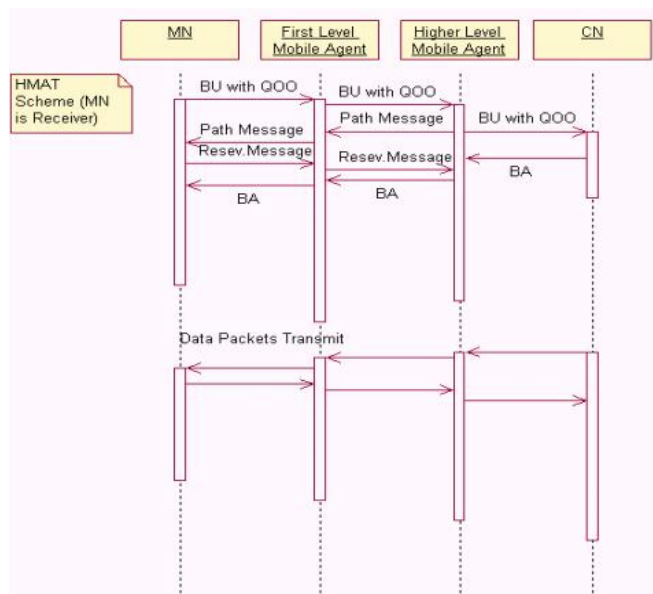

Fig. 6. Sequence Diagram of the HMAT Scheme (MN is Receiver)

4 Simulation Results

We use the OPNET Modeler v8.0 to simulate our scheme and compare our scheme with RSVP Mobility Based on Multicast Tree [9]. For simplicity our simulation is based on an assumption that the capacity of the links between the mobile agents is not limited. And we only considered the unicast data flows from a single mobile sender roaming freely in wireless domain to a fixed static receiver for simplicity. Figure 7 shows the network topology used for our simulation. There are two cells in this network, and each cell has a mobile agent as the first type mobile agent in HMAT that has two levels.

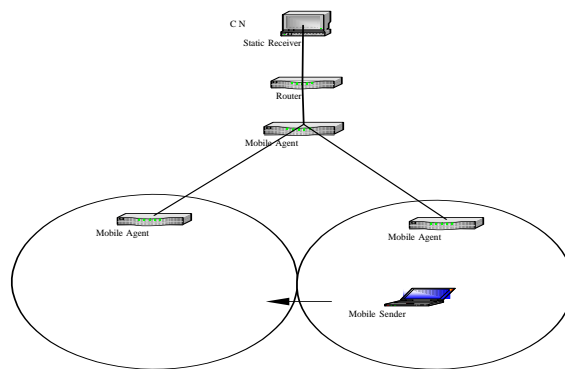

Fig. 7. Network Configuration for Simulation

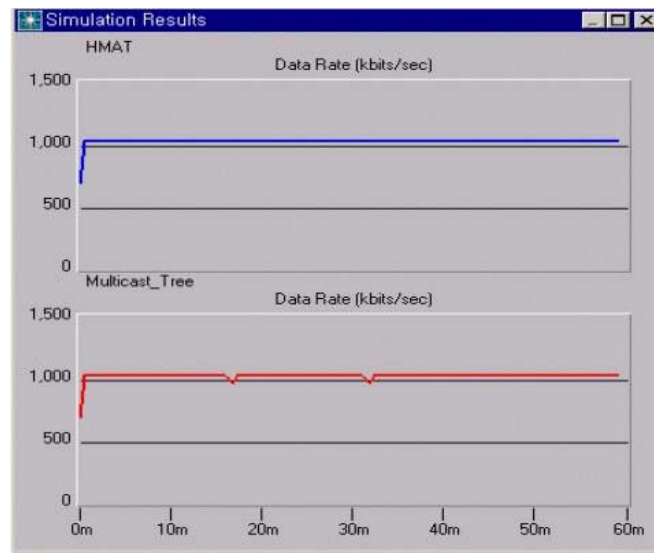

Fig. 8. Simulation Results (Data Rate)

The goal of our simulation work is for evaluating the QoS, such as data rate, packet loss ratio and packet delay, by using our scheme and comparing with RSVP Mobility Based on Multicast Tree [9] when the handoff occurs. We use a real time traffic source at a peak rate of 1Mbps to get the variations of data rate, packet loss ratio and packet delay received by the fixed static receiver CN due to the handoff.

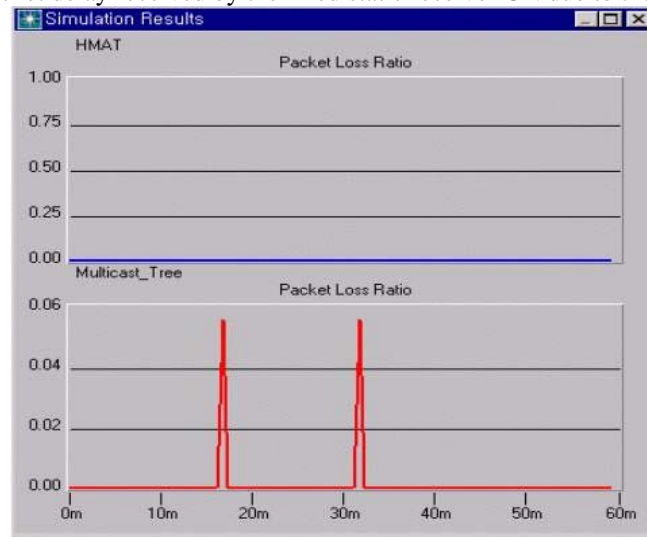

Fig. 9. Simulation Results (Packet Loss Ratio)

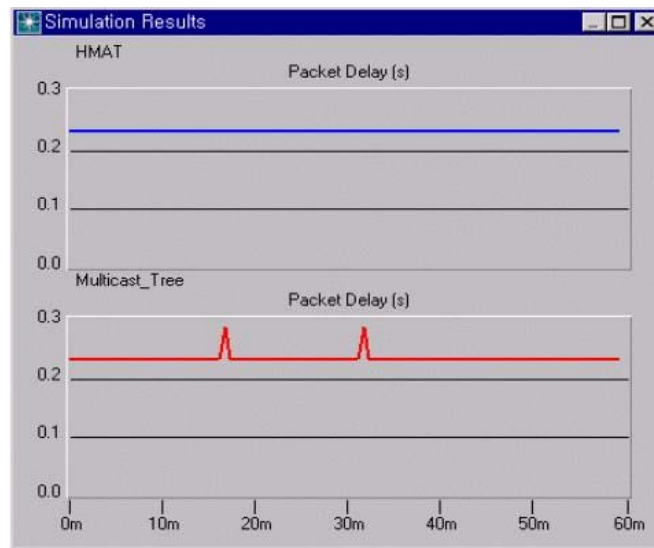

Fig. 10. Simulation Results (Packet Delay)

Figure 8 shows the simulation results of the data rate using our HMAT scheme and Multicast Tree scheme over simulation time. In these figures, the X-axis represents the simulation time (minute) and the Y-axis represents the relative data rate (kbps). We can see that the data rate of Multicast Tree scheme is obviously decreased at the moment a handoff takes place, and our HMAT scheme has a real smooth handoff.

Figure 9 shows the simulation results of the packet loss ratio. The results show that the packet loss ratio of the Multicast Tree scheme is more than that of the HMAT scheme when handoff takes place.

Figure 10 shows the simulation results of the packet delay. The results also show that the Multicast Tree scheme has more packet delay than our HMAT scheme when handoff takes place.

These simulation results have the following reasons. First, in the Multicast Tree scheme, when the handoff occurs, the Binding Update is sent to the CN and the mobile node receives the Binding Acknowledgment, then the Multicast Tree should be modified dynamically and some QoS signaling messages should be used, the new Conventional Reservation and all of the Predictive Reservations should be made again, then the data packets is be sent continually. Second, in our HMAT scheme, there are no any extra QoS setting up delay due to handoff. Therefore the Multicast Tree scheme has more QoS signaling delay, packet loss ratio, data packet delay and lower data rate than our HMAT scheme whenever a handoff occurs.

In summary, our scheme that extends RSVP using the HMAT based on the QOO provides more efficient QoS signaling mechanism in the Integrated Service Internet with mobile hosts. We reduce the QoS signaling delay, packet loss ratio and packet delay, get higher data rate for real time multimedia applications when handoff occurs.

5 Conclusions

In this paper, a novel framework for QoS support in Mobile IPv6 using the HMAT based on QOO [11] in Integrated Services Internet has been proposed. HMAT can be configured and chosen by the network administrator in any way. Mobile agent can manage QOO, resource reservation and other mobility related works. Mobile agent can be divided into two types according to its function. When a mobile host moves to a new location, the RSVP will be made a Local Repair only between the mobile host and some mobile agent of HMAT in a part of the route where the Binding Update and Binding Acknowledgment are traversed between the MN and the CN. Therefore, our scheme can provide smooth handoff, more efficient QoS provision.

Moreover, we use OPNET Modeler to simulate our scheme and compare with RSVP Mobility Based on Multicast Tree [9]. The simulation results prove that our scheme can provide higher data rate, lower packet delay and packet loss ratio, and improve the efficiency by using HMAT based on QOO when handoff takes place in Mobile IPv6.

In the future, we will keep on researching to give more efficient QoS support in Core Network over MPLS based on the Mobile IPv6 and QOO.

Acknowledgement

This work was supported by Korea Research Foundation Grant. (KRF-2001-003-E00201)

References

1. C.Perkins, " IP Mobility Support, " RFC 2002, October 1996.
2. D.B.Johnson and C.Perkins, " Mobility Support in IPv6, " IETF Internet-Draft, work in progress, November 2000.
3. R.Braden, L.Zhang, S.Berson, S.Herzog, and S.Jamin, " Resource ReSerVation Protocol (RSVP) Version 1 Functional Specification, " RFC 2205, September 1997.
4. J.Wrclawski, " The Use of RSVP with IETF Integrated Services, " RFC 2210, September 1997.
5. A.Terzis, J.Krawczyk, J.Wroclawski, L.Zhang, " RSVP Operation Over IP Tunnels, " RFC 2746, January 2000.
6. A.K.Talukdar, B.R.Badrinath, and A.Acharya, " MRSVP: A Reservation Protocol for an Integrated Services packet Network with Mobile Hosts, " Tech. Rep. Dcs-tr-337, Department of Computer Science, Rutgers University, U.S.A., 1997.
7. I.Mahadevan and K.M.Sivalingam, " An Experimental Architecture for providing QoS guarantees in Mobile Networks using RSVP, " IEEE PIMRC, Boston, September 1998.
8. A.Terzis and M.Srivastava and L.Zhang, " A Simple QoS Signaling Protocol for Mobile Hosts in the Integrated Services Internet, " INFOCOM 1999.
9. W.Chen and L.Huang, " RSVP Mobility Support: A Signaling Protocol for Integrated Services internet with Mobile Hosts, " INFOCOM 2000.
10. Qi.Shen and W.Seah and A.Lo, " Flow Transparent Mobility and QoS Support for IPv6-based Wireless Real-time Services, " IETF Internet-Draft, work in progress, February 2001.
11. H.Chaskar and R.Koodli, " A Framework for QoS Support in Mobile IPv6, " IETF Internet-Draft, work in progress, March 2001.
12. ZhaoWei Qu and ChoongSeon Hong, " QoS Provision Architecture for Mobile IP using RSVP, " Proceedings of KICS National Conference, Vol.23, pp.1551, Cheju, Korea, July 2001.